

# ALPHA

## Pendant control station



Pendant control station for auxiliary control with an innovative and modern design, where all graphic elements refer to specific technical functions. Size and shape of Alpha guarantee easy handling as a result of a thorough analysis of the ergonomic features combined with the research of a graphic style suitable for a modern industrial environment.

### FEATURES

- Reduced installation and wiring time and costs: the switches feature terminals facing the cable clamp of the control station and screws on the opposite side to facilitate wiring.
- The control station has an angle of inclination giving the operator the best view of all control elements and enabling a natural, comfortable working position.
- The emergency stop mushroom pushbutton complies with standard ISO 13850.
- Mechanical life of switches: 1 million operations.
- IP protection degree: Alpha is classified IP 65.
- Extreme temperature resistance: -25°C to +70°C.
- All materials and components used are wear resistant and guarantee protection of the unit against water and dust.

### OPTIONS

- Available in configurations with 2 to 13 actuators arranged on a double row.
- Single or double switches with NO or NC contacts featuring one or two speeds.
- Wide range of actuators: pushbuttons, selector switches and key-selector switches in different configurations, pilot lights, latched mushrooms pushbuttons with rotation or key-operated release.
- Available with label (symbols and lettering) to be applied next to the actuators.

### CERTIFICATIONS

- CE marking.

*Fill in the "request form" for accurate product configuration.*

## CERTIFICATIONS

Conformity to Community Directives	2014/35/UE Low Voltage Directive
	2006/42/CE Machinery Directive
Conformity to CE Standards	EN 60204-1 Safety of machinery - Electrical equipment of machines
	EN 60947-1 Low-voltage switchgear and controlgear
	EN 60947-5-1 Low-voltage switchgear and controlgear - Control circuit devices and switching elements - Electromechanical control circuit devices
	EN 60529 Degrees of protection provided by enclosures
Markings and homologations	ISO 13850 Safety of machinery - Emergency stop - Principles for design
	CE

## GENERAL TECHNICAL SPECIFICATIONS

Ambient temperature	Storage -40°C/+70°C
	Operational -25°C/+70°C
IP protection degree	IP 65
Insulation category	Class II
Cable entry	Rubber cable sleeve (Ø 14÷26 mm)
Operating positions	Any position

## TECHNICAL SPECIFICATIONS OF THE SWITCHES

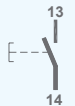
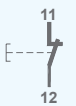
Code	PRSL1000PI	PRSL1001PI
Utilisation category		AC 15
Rated operational current		3 A
Rated operational voltage		250 Vac
Rated thermal current		10 A
Rated insulation voltage		500 Vac
Mechanical life		1x10 <sup>6</sup> operations
Connections		Screw-type terminals
Wires		1x2.5 mm <sup>2</sup> , 2x1.5 mm <sup>2</sup> (UL - (c)UL: use 60°C or 75°C copper (CU) conductor and wire 16-18 AWG)
Tightening torque		0.6 Nm
Switch type	Double break, slow action	Double break, slow action
Contacts	1NO	1NC
Scheme		
Markings and homologations		CE cULus

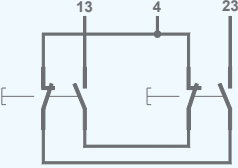
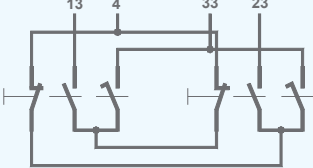
Code	PRSL1002PI	PRSL1003PI
Utilisation category	AC 15	
Rated operational current	3 A	
Rated operational voltage	250 Vac	
Rated thermal current	10 A	
Rated insulation voltage	500 Vac	
Mechanical life	1x10 <sup>6</sup> operations	
Connections	Screw-type terminals	
Wires	1x2.5 mm <sup>2</sup> , 2x1.5 mm <sup>2</sup> (UL - (c)UL: use 60°C or 75°C copper (CU) conductor and wire 16-18 AWG)	
Tightening torque	0.6 Nm	
Switch type	Double switch, 1 speed	Double switch, 2 speeds
Contacts	2NO+common	3NO+common
Scheme		
Markings and homologations	CE cULus	

## TECHNICAL SPECIFICATIONS OF THE LAMP HOLDERS

Code	PRSL1004PI
Maximum voltage	125 V
Maximum power	2.6 W
Lamp type (not supplied)	T5.5K 22 mm
Connections	Screw-type terminals
Wires	1x2.5 mm <sup>2</sup> , 2x1.5 mm <sup>2</sup>
Tightening torque	0.6 Nm
Markings and homologations	CE

## OVERALL DIMENSIONS (mm)

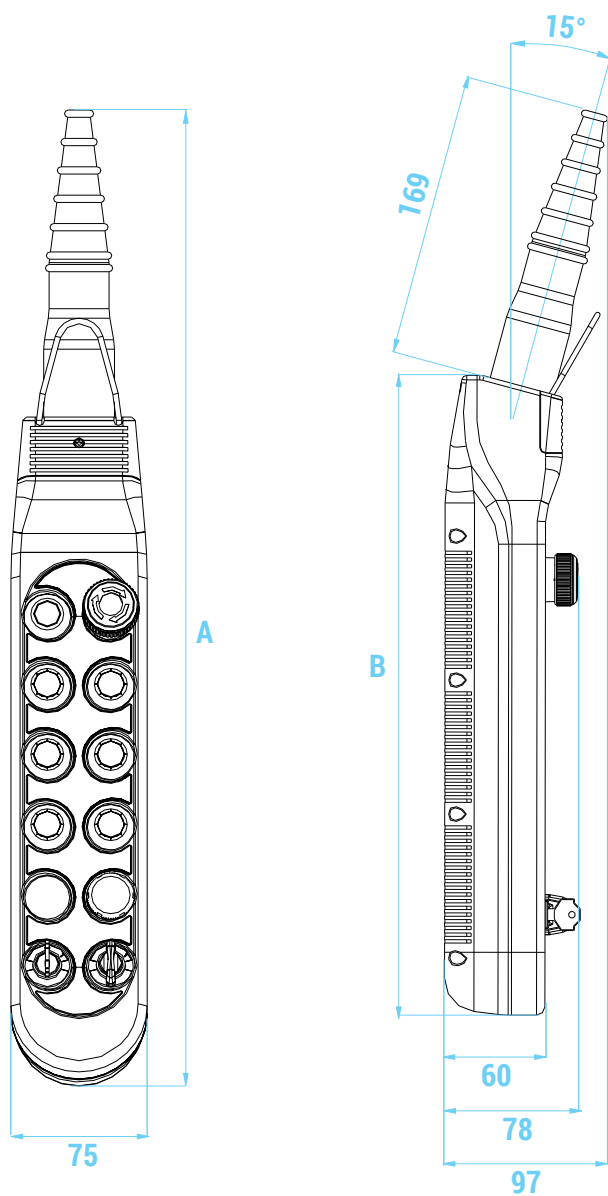





No. of actuators	Dimensions (mm)	
	A	B
2 - 3 - 4 - 5	382	222
6 - 7 - 8 - 9	462	302
10 - 11 - 12 - 13	542	382



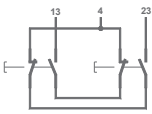

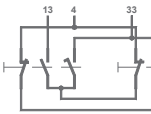

## STANDARD CONTROL STATIONS

Standard control stations are equipped with cable sleeve, hook and electrical interlock between opposite function pushbuttons.



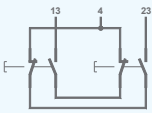

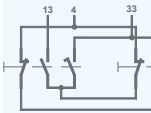



### 2 actuators



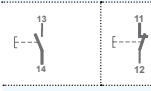

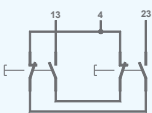

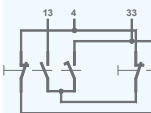

PF38020005				PF38020002			
Switch scheme	Switches	Actuators		Switch scheme	Switches	Actuators	
	N.1 PRSL1002PI 2NO+common 1 speed	Pushbutton 	Pushbutton 		N.1 PRSL1003PI 3NO+comune 2 speeds	Pushbutton 	Pushbutton 
-	-	Blanking plug	Blanking plug	-	-	Blanking plug	Blanking plug

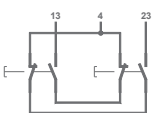
### 3 actuators

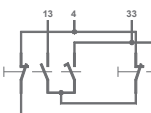
PF38030001				PF38030002			
Switch scheme	Switches	Actuators		Switch scheme	Switches	Actuators	
	N.1 PRSL1001PI 1NC	Latched mushroom pushbutton			N.1 PRSL1001PI 1NC	Latched mushroom pushbutton	
	N.1 PRSL1002PI 2NO + common 1 speed	Pushbutton 	Pushbutton 		N.1 PRSL1003PI 3NO+common 2 speeds	Pushbutton 	Pushbutton 
-	-	Blanking plug	Blanking plug	-	-	Blanking plug	Blanking plug

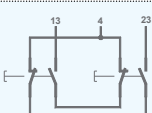
### 4 actuators

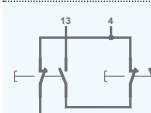
PF38040002				PF38040003					
Switch scheme	Switches	Actuators		Switch scheme	Switches	Actuators			
	N.1 PRSL1000PI 1NO	N.1 PRSL1001PI 1NC	Pushbutton 	Latched mushroom pushbutton		N.1 PRSL1000PI 1NO	N.1 PRSL1001PI 1NC	Pushbutton 	Latched mushroom pushbutton
	N.1 PRSL1002PI 2NO + common 1 speed	Pushbutton 	Pushbutton 		N.1 PRSL1003PI 3NO+common 2 speeds	Pushbutton 	Pushbutton 		

PF38040004				PF38040006			
Switch scheme	Switches	Actuators		Switch scheme	Switches	Actuators	
	N.1 PRSL1002PI 2NO+common 1 speed	Pushbutton 	Pushbutton 		N.1 PRSL1003PI 3NO+common 2 speeds	Pushbutton 	Pushbutton 
	N.1 PRSL1002PI 2NO+common 1 speed	Pushbutton 	Pushbutton 		N.1 PRSL1002PI 2NO+common 1 speed	Pushbutton 	Pushbutton 

## PF38040012

Switch scheme	Switches	Actuators
	N.2 PRSL1000PI 1NO N.1 PRSL1001PI 1NC	Pushbutton Latched mushroom pushbutton 
	PRSL1003PI 3NO+common 2 speeds	Pushbutton Pushbutton 

## PF38040016

Switch scheme	Switches	Actuators
	N.2 PRSL1000PI 1NO N.1 PRSL1001PI 1NC	Pushbutton Latched mushroom pushbutton 
	N.1 PRSL1002PI 2NO + common 1 speed	Pushbutton Pushbutton 

## 5 actuators

## PF38050003

Switch scheme	Switches	Actuators
	N.1 PRSL1001PI 1NC	Latched mushroom pushbutton
	N.1 PRSL1002PI 2NO + common 1 speed	Pushbutton Pushbutton 
	N.1 PRSL1002PI 2NO+common 1 speed	Pushbutton Pushbutton 

## PF38050004

Switch scheme	Switches	Actuators
	N.1 PRSL1001PI 1NC	Latched mushroom pushbutton
	N.1 PRSL1003PI 3NO+common 2 speeds	Pushbutton Pushbutton 
	N.1 PRSL1002PI 2NO+common 1 speed	Pushbutton Pushbutton 

## PF38050005

Switch scheme	Switches	Actuators
	N.1 PRSL1001PI 1NC	Latched mushroom pushbutton
	N.1 PRSL1003PI 3NO+common 2 speeds	Pushbutton Pushbutton 
	N.1 PRSL1003PI 3NO+common 2 speeds	Pushbutton Pushbutton 

## 6 actuators









## PF38060001

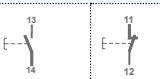

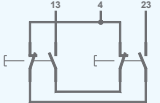

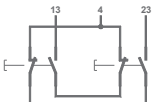

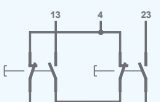

Switch scheme	Switches	Actuators
	N.2 PRSL1000PI 1NO N.1 PRSL1001PI 1NC	Pushbutton Latched mushroom pushbutton 
	N.1 PRSL1002PI 2NO + common 1 speed	Pushbutton Pushbutton 
	N.1 PRSL1002PI 2NO+common 1 speed	Pushbutton Pushbutton 
-	-	Blanking plug Blanking plug

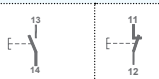

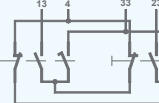

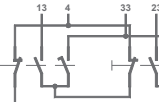

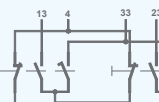

## PF38060002

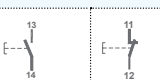

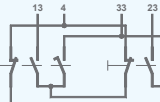

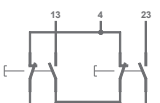

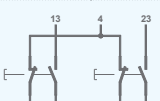

Switch scheme	Switches	Actuators
	N.2 PRSL1000PI 1NO N.1 PRSL1001PI 1NC	Pushbutton Latched mushroom pushbutton 
	N.1 PRSL1003PI 3NO+common 2 speeds	Pushbutton Pushbutton 
	N.1 PRSL1003PI 3NO+common 2 speeds	Pushbutton Pushbutton 
-	-	Blanking plug Blanking plug

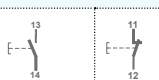

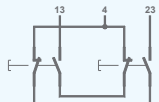

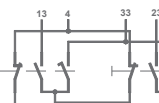

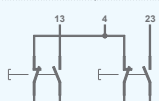

## 8 actuators

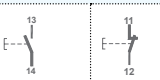
PF38080001				
Switch scheme	Switches	Actuators		
	N.2 PRSL1000PI 1NO	N.1 PRSL1001PI 1NC	Pushbutton 	Latched mushroom pushbutton
	N.1 PRSL1002PI 2NO + common 1 speed		Pushbutton 	Pushbutton 
	N.1 PRSL1002PI 2NO + common 1 speed		Pushbutton 	Pushbutton 
	N.1 PRSL1002PI 2NO + common 1 speed		Pushbutton 	Pushbutton 

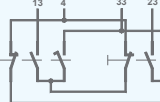
PF38080002				
Switch scheme	Switches	Actuators		
	N.2 PRSL1000PI 1NO	N.1 PRSL1001PI 1NC	Pushbutton 	Latched mushroom pushbutton
	N.1 PRSL1003PI 3NO+common 2 speeds		Pushbutton 	Pushbutton 
	N.1 PRSL1003PI 3NO+common 2 speeds		Pushbutton 	Pushbutton 
	N.1 PRSL1003PI 3NO+common 2 speeds		Pushbutton 	Pushbutton 

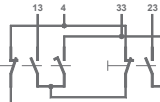
PF38080006				
Switch scheme	Switches	Actuators		
	N.2 PRSL1000PI 1NO	N.1 PRSL1001PI 1NC	Pushbutton 	Latched mushroom pushbutton
	N.1 PRSL1003PI 3NO+common 2 speeds		Pushbutton 	Pushbutton 
	N.1 PRSL1002PI 2NO+common 1 speed		Pushbutton 	Pushbutton 
	N.1 PRSL1002PI 2NO+common 1 speed		Pushbutton 	Pushbutton 

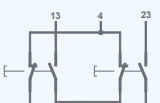
PF38080007				
Switch scheme	Switches	Actuators		
	N.2 PRSL1000PI 1NO	N.1 PRSL1001PI 1NC	Pushbutton 	Latched mushroom pushbutton
	N.1 PRSL1002PI 2NO + common 1 speed		Pushbutton 	Pushbutton 
	N.1 PRSL1003PI 3NO+common 2 speeds		Pushbutton 	Pushbutton 
	N.1 PRSL1002PI 2NO+common 1 speed		Pushbutton 	Pushbutton 

PF38080008				
Switch scheme	Switches	Actuators		
	N.2 PRSL1000PI 1NO	N.1 PRSL1001PI 1NC	Pushbutton 	Latched mushroom pushbutton
	N.1 PRSL1003PI 3NO+common 2 speeds		Pushbutton 	Pushbutton 
	N.1 PRSL1003PI 3NO+common 2 speeds		Pushbutton 	Pushbutton 
	N.1 PRSL1002PI 2NO+common 1 speed		Pushbutton 	Pushbutton 

## 10 actuators

PF3810001				
Switch scheme	Switches	Actuators		
	N.2 PRSL1000PI 1NO	N.1 PRSL1001PI 1NC	Pushbutton 	Latched mushroom pushbutton
	N.1 PRSL1002PI 2NO + common 1 speed		Pushbutton 	Pushbutton 
	N.1 PRSL1002PI 2NO+common 1 speed		Pushbutton 	Pushbutton 
	N.1 PRSL1002PI 2NO+common 1 speed		Pushbutton 	Pushbutton 
-	-		Blanking plug	Blanking plug

## 12 actuators

PF3812001				
Switch scheme	Switches	Actuators		
	N.2 PRSL1000PI 1NO	N.1 PRSL1001PI 1NC	Pushbutton 	Latched mushroom pushbutton
	N.1 PRSL1002PI 2NO + common 1 speed		Pushbutton 	Pushbutton 
	N.1 PRSL1002PI 2NO + common 1 speed		Pushbutton 	Pushbutton 
	N.1 PRSL1002PI 2NO+common 1 speed		Pushbutton 	Pushbutton 
	N.1 PRSL1002PI 2NO+common 1 speed		Pushbutton 	Pushbutton 
	N.1 PRSL1002PI 2NO+common 1 speed		Pushbutton 	Pushbutton 

## STANDARD PENDANT CONTROL STATIONS WITH CABLE OUTPUT ON THE BOTTOM

These pendant control stations are upside down, i.e. the cable output is on the bottom.

Standard control stations are equipped with cable sleeve, hook and electrical interlock between opposite function pushbuttons.

## 10 actuators

PF3810002				
Switch scheme	Switches	Actuators		
	N.1 PRSL1000PI 1NO	N.1 PRSL1000PI 1NO	Pushbutton 	Pushbutton 
	N.1 PRSL1000PI 1NO	N.1 PRSL1001PI 1NC	Pushbutton 	Latched mushroom pushbutton
	N.1 PRSL1002PI 2NO + common 1 speed		Pushbutton 	Pushbutton 
	N.1 PRSL1002PI 2NO+common 1 speed		Pushbutton 	Pushbutton 
	N.1 PRSL1002PI 2NO+common 1 speed		Pushbutton 	Pushbutton 
-	-		Blanking plug	Blanking plug

## 12 actuators

PF3812002				
Switch scheme	Switches	Actuators		
	N.1 PRSL1000PI 1NO	N.1 PRSL1000PI 1NO	Pushbutton 	Pushbutton 
	N.1 PRSL1000PI 1NO	N.1 PRSL1001PI 1NC	Pushbutton 	Latched mushroom pushbutton
	N.1 PRSL1002PI 2NO + common 1 speed		Pushbutton 	Pushbutton 
	N.1 PRSL1002PI 2NO+common 1 speed		Pushbutton 	Pushbutton 
	N.1 PRSL1002PI 2NO+common 1 speed		Pushbutton 	Pushbutton 
	N.1 PRSL1002PI 2NO+common 1 speed		Pushbutton 	Pushbutton 



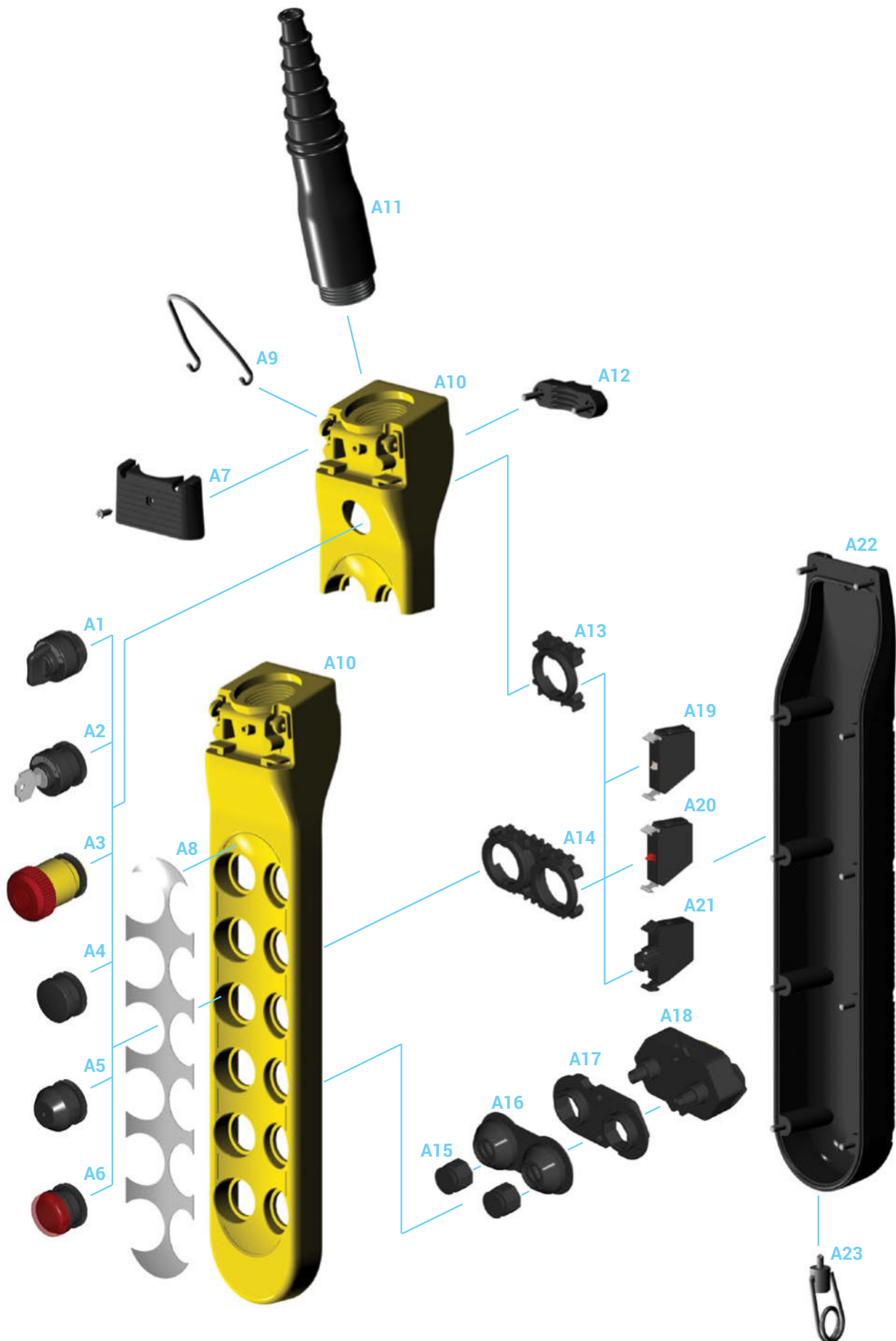







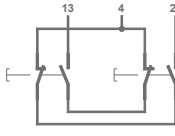
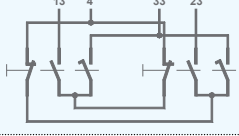



Refer to the following tables for descriptions of components: "Switches", "Actuators", "Pilot lights", "Mushroom pushbuttons", "Selector switches" and "Accessories".

## COMPONENTS

## Switches

Ref.	Drawing	Description	Scheme	Code
A18		Double switch, 1 speed, 2NO + common		PRSL1002PI
		Double switch, 2 speeds, 3NO + common		PRSL1003PI
A19		1NO switch		PRSL1000PI
A20		1NC switch		PRSL1001PI
A21		Lamp holder (without bulb)	-	PRSL1004PI

## Actuators

Ref.	Drawing	Description	Code
A4		Blanking plug	PRSL1023PI
A5		Single pushbutton	PRTS000001
A15+A16		Double pushbutton with rubber	PRTD000001
A16		Rubber for double pushbutton	PRGO0020PE
A17		Holding plate for double pushbutton	PRSL8737PI

## Pilot lights

Ref.	Drawing	Colour	Code
A6		Red	PRSL1012PI
		Yellow	PRSL1013PI
		Green	PRSL1014PI

## Mushroom pushbuttons

Ref.	Drawing	Description	Code
A3		Latched mushroom pushbutton for emergency stop	PRSL1009PI

## Toggle selector switches

Ref.	Drawing	Positions	Position on control station *			Code
			A	B	C	
A1		0-1 Spring return		x	x	PRSL1040PI
		0-1 Spring return	x			PRSL1041PI
		0-1 Maintained positions		x	x	PRSL1029PI
		0-1 Maintained positions	x			PRSL1030PI
		1-0-2 Spring return		x		PRSL1026PI
		1-0-2 Spring return	x			PRSL1042PI
		1-0-2 Maintained positions		x		PRSL1027PI
		1-0-2 Maintained positions	x			PRSL1031PI
		1-0-2 Maintained positions - Symbols I-I + II-II		x		PRSL1063PI
		1-0-2 Pos. 1 manteined - Pos. 2 spring return		x		PRSL1038PI
1-2 Maintained positions		x		PRSL1034PI		

## Key selector switches

Ref.	Drawing	Positions	Position on control station *			Code
			A	B	C	
A2		0-1 Spring return		x	x	PRSL1024PI
		0-1 Spring return	x			PRSL1049PI
		0-1 Maintained positions		x	x	PRSL1046PI
		0-1 Maintained positions	x			PRSL1047PI
		1-0-2 Spring return		x		PRSL1059PI
		1-0-2 Spring return	x			PRSL1043PI
		1-0-2 Maintained positions		x		PRSL1048PI
		1-0-2 Maintained positions	x			PRSL1050PI
		1-0-2 Spring return Simultaneous activation of 2 switches		x		PRSL1057PI



### \* Position on control station:

A = central position, with vertical holding plate for 3 switches.





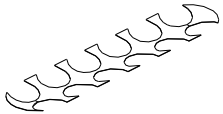

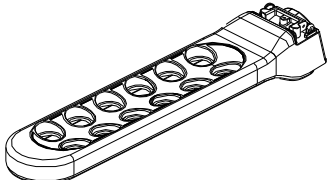
B = first and last double rows, with holding plate for 3+3 switches.

C = central double rows, with holding plate for 2+2 switches.

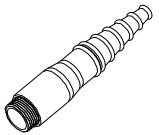
## Accessories

Ref.	Drawing	Description	Code
A7		Cable cover	PRSL5603PI
A8		Label	ET38xxxxxx Codes on request
A9		Hook	PRGA0020PE
A10		Cover 2/4 actuators	PRSL5607PI
		Cover 3/5 actuators	PRSL5611PI
		Cover 6/8 actuators	PRSL5608PI
		Cover 7/9 actuators	PRSL5612PI
		Cover 10/12 actuators	PRSL5609PI
		Cover 11/13 actuators	PRSL5613PI

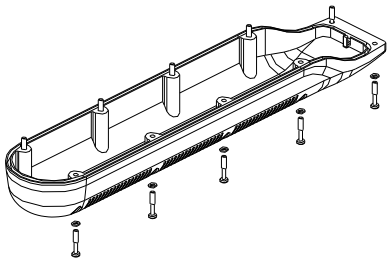
## Accessories

Ref.	Drawing	Description	Code
A11		Cable sleeve	PRSL0145PE
A12		Cable clamp	PRSL1020PI
A13		Holding plate for 3 switches	PRSL8739PI
A14		Holding plate for 2+2 switches	PRSL8735PI
A22		Enclosure 2/3/4/5 actuators with gasket	SL000111R
		Enclosure 6/7/8/9 actuators with gasket	PRSL5067PI
		Enclosure 10/11/12/13 actuators with gasket	PRSL5068PI
A23		Lower hook	PRGA0051PE

# ALPHA - REQUEST FORM FOR NON STANDARD CONTROL STATION

## Instructions

(See next page for list of components and legends).

Fill in the chart to the left according to the number of control elements required.

**1 Control elements:** enter the number corresponding to the control element required in the circle (1 to 27) according to the legend.

ATTENTION: selector switches can be mounted only in specific positions, as specified in the switch activation schemes (see legend).

**2 Label symbols:** in the broken-line box enter the number corresponding to the symbol required on the label (50 to 68) according to the legend.

Next to the number mark the direction of the arrow and the customized lettering, if requested.

**3 Switches:** in the unbroken boxes enter the letters corresponding to the single or double switches required (A to E) according to the legend.

**4 Cable sleeve and hook:** tick the appropriate boxes to show where the cable sleeve and the hook must be assembled (top or bottom).

## 1 Legend - Control elements

### \* SWITCH ACTIVATION

It is possible to mount up to 2 switches for each selector switch, but no switch in the central position (NA). You can mount the selector switch in the central position when the scheme shows a vertical holding plate for 3 switches, in the first and last double row when there is a holding plate for 3+3 switches, or in the double central rows when there is a holding plate for 2+2 switches. The scheme also shows which position of the selector operates on each switch.

### Pushbuttons

- ① PRTD000001 Double pushbutton
- ② PRTS000001 Single pushbutton

### Blanking plugs and mushroom pushbuttons

- ③ PRSL1023PI Blanking plug
- ④ PRSL1009PI Emergency stop mushroom pushbutton

### Toggle selector switches

	SWITCH ACTIVATION*												
⑧ PRSL1040PI 0-1 spring return	<table border="1"><tr><td>1</td><td>NA</td><td>1</td><td>1</td><td>NA</td><td>1</td></tr><tr><td></td><td>NA</td><td>1</td><td>1</td><td>NA</td><td></td></tr></table>	1	NA	1	1	NA	1		NA	1	1	NA	
1	NA	1	1	NA	1								
	NA	1	1	NA									
⑨ PRSL1041PI 0-1 spring return	<table border="1"><tr><td>1</td></tr><tr><td>NA</td></tr><tr><td>1</td></tr></table>	1	NA	1									
1													
NA													
1													
⑩ PRSL1029PI 0-1 maintained positions	<table border="1"><tr><td>1</td><td>NA</td><td>1</td><td>1</td><td>NA</td><td>1</td></tr><tr><td></td><td>NA</td><td>1</td><td>1</td><td>NA</td><td></td></tr></table>	1	NA	1	1	NA	1		NA	1	1	NA	
1	NA	1	1	NA	1								
	NA	1	1	NA									
⑪ PRSL1030PI 0-1 maintained positions	<table border="1"><tr><td>1</td></tr><tr><td>NA</td></tr><tr><td>1</td></tr></table>	1	NA	1									
1													
NA													
1													
⑫ PRSL1026PI 1-0-2 spring return	<table border="1"><tr><td>1</td><td>NA</td><td>2</td><td>1</td><td>NA</td><td>2</td></tr></table>	1	NA	2	1	NA	2						
1	NA	2	1	NA	2								
⑬ PRSL1042PI 1-0-2 spring return	<table border="1"><tr><td>2</td></tr><tr><td>NA</td></tr><tr><td>1</td></tr></table>	2	NA	1									
2													
NA													
1													
⑭ PRSL1027PI 1-0-2 maintained positions	<table border="1"><tr><td>1</td><td>NA</td><td>2</td><td>1</td><td>NA</td><td>2</td></tr></table>	1	NA	2	1	NA	2						
1	NA	2	1	NA	2								
⑮ PRSL1031PI 1-0-2 maintained positions	<table border="1"><tr><td>2</td></tr><tr><td>NA</td></tr><tr><td>1</td></tr></table>	2	NA	1									
2													
NA													
1													
⑯ PRSL1063PI 1-0-2 maintained positions symbols I-I + II-II	<table border="1"><tr><td>1</td><td>NA</td><td>2</td><td>1</td><td>NA</td><td>2</td></tr></table>	1	NA	2	1	NA	2						
1	NA	2	1	NA	2								
⑰ PRSL1038PI 1-0-2 position 1 mantened position 2 spring return	<table border="1"><tr><td>1</td><td>NA</td><td>2</td><td>1</td><td>NA</td><td>2</td></tr></table>	1	NA	2	1	NA	2						
1	NA	2	1	NA	2								
⑱ PRSL1034PI 1-2 maintained positions	<table border="1"><tr><td>1</td><td>NA</td><td>2</td><td>1</td><td>NA</td><td>2</td></tr></table>	1	NA	2	1	NA	2						
1	NA	2	1	NA	2								

### Pilot lights

- ⑤ PRSL1012PI Red pilot light
- ⑥ PRSL1013PI Yellow pilot light
- ⑦ PRSL1014PI Green pilot light

### Key selector switches

	SWITCH ACTIVATION*												
⑰ PRSL1024PI 0-1 spring return	<table border="1"><tr><td>1</td><td>NA</td><td>1</td><td>1</td><td>NA</td><td>1</td></tr><tr><td></td><td>NA</td><td>1</td><td>1</td><td>NA</td><td></td></tr></table>	1	NA	1	1	NA	1		NA	1	1	NA	
1	NA	1	1	NA	1								
	NA	1	1	NA									
⑳ PRSL1049PI 0-1 spring return	<table border="1"><tr><td>1</td></tr><tr><td>NA</td></tr><tr><td>1</td></tr></table>	1	NA	1									
1													
NA													
1													
㉑ PRSL1046PI 0-1 maintained positions	<table border="1"><tr><td>1</td><td>NA</td><td>1</td><td>1</td><td>NA</td><td>1</td></tr><tr><td></td><td>NA</td><td>1</td><td>1</td><td>NA</td><td></td></tr></table>	1	NA	1	1	NA	1		NA	1	1	NA	
1	NA	1	1	NA	1								
	NA	1	1	NA									
㉒ PRSL1047PI 0-1 maintained positions	<table border="1"><tr><td>1</td></tr><tr><td>NA</td></tr><tr><td>1</td></tr></table>	1	NA	1									
1													
NA													
1													
㉓ PRSL1059PI 1-0-2 spring return	<table border="1"><tr><td>1</td><td>NA</td><td>2</td><td>1</td><td>NA</td><td>2</td></tr></table>	1	NA	2	1	NA	2						
1	NA	2	1	NA	2								
㉔ PRSL1043PI 1-0-2 spring return	<table border="1"><tr><td>2</td></tr><tr><td>NA</td></tr><tr><td>1</td></tr></table>	2	NA	1									
2													
NA													
1													
㉕ PRSL1048PI 1-0-2 maintained positions	<table border="1"><tr><td>1</td><td>NA</td><td>2</td><td>1</td><td>NA</td><td>2</td></tr></table>	1	NA	2	1	NA	2						
1	NA	2	1	NA	2								
㉖ PRSL1050PI 1-0-2 maintained positions	<table border="1"><tr><td>2</td></tr><tr><td>NA</td></tr><tr><td>1</td></tr></table>	2	NA	1									
2													
NA													
1													
㉗ PRSL1057PI 1-0-2 spring return simultaneous activation of 2 switches	<table border="1"><tr><td>1-2</td><td>NA</td><td>1-2</td><td>1-2</td><td>NA</td><td>1-2</td></tr></table>	1-2	NA	1-2	1-2	NA	1-2						
1-2	NA	1-2	1-2	NA	1-2								

## 2 Legend - Label symbols

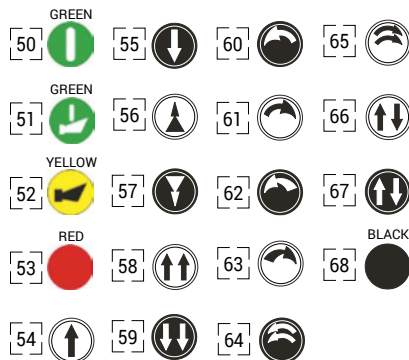

## 3 Legend - Switches

### Single switches

- A PRSL1000PI 1NO
- B PRSL1001PI 1NC
- C PRSL1004PI Lamp holder (without bulb)

### Double switches

- D PRSL1002PI 1 speed
- E PRSL1003PI 2 speeds